

Agathon Fine centering Plus for mold construction | 7990/7992/7993/7995

Program expansion



AGATHON
S W I T Z E R L A N D

How it is applied...

The patented Agathon Fine Centering Plus with its rolling and preloaded rollers ensures low-wear operation with maximum precision. This ensures that mold halves are precisely closed, sliders move synchronously and the plastic parts are gently demolded.

Tool requirements are constantly increasing, both in cleanroom production and for technical plastic parts. These requirements can be met with Agathon Fine Centering Plus.

Depending on the space available, two or more Agathon Fine Centering Plus units can be used. The design engineer is free to design the arrangement. The load capacity and the desired lifespan are decisive for the number of fine centering Plus units installed.



Agathon Fine Centering Plus

Application examples

1. Agathon Fine Centering Plus for guiding the ejector plate and centering of the main separation level.
2. Upgrade from conventional guide block to Agathon Fine Centering Plus.

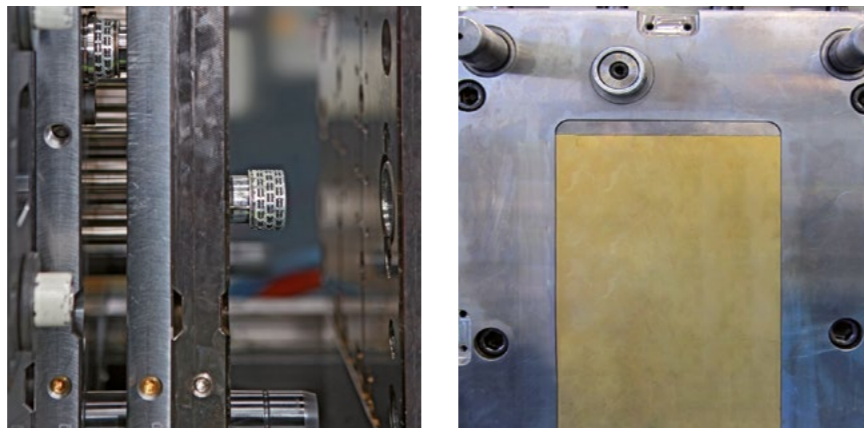

Cost comparison with conventional guide blocks...

Cost for first fitting Number of guide blocks compared to Fine Centering Plus	4 ¹⁾ to 4	4 ¹⁾ to 2	4 ¹⁾ to 6
Purchase price of the centering and machining costs for the location pockets	93% approx. same size	58% greater size	118% smaller size

¹⁾ Number of conventional guide blocks

100% = conventional guide block

Advantages of the Agathon concept

- Thanks to a precise axial positioning of the roller cage at the centering start almost two rows of rollers are simultaneously engaged in the preload – this guarantees a high initial load capacity and a long service life. The initial load capacity with two rows of rollers engaged is equivalent to 16 rows of balls
- Low wear due to rolling centering. Conventional guide block reach a low-wear "sliding" centering only after a sufficient overlapping of the two centering surfaces. Especially at centering start (line contact), the surface pressure "p" exceeds the permissible value (p_{zul}) several times
- The lifespan of the unit can be extended by rotating the fine centering unit by 120° to 180° at the time
- Heat resistant up to approx. 150° C (302° Fahrenheit)
- Lower total cost, low manufacturing cost of the cylindrical location bore
- Little to no maintenance, they can be used with minimal lubrication
- Excellent design freedom
- Durability – Mass production
- Backlash-free
- Short cycle times
- High initial load capacity at centering start
- No noticeable wear – Cleanroom production

Maximum load capacity in comparison to conventional guide blocks

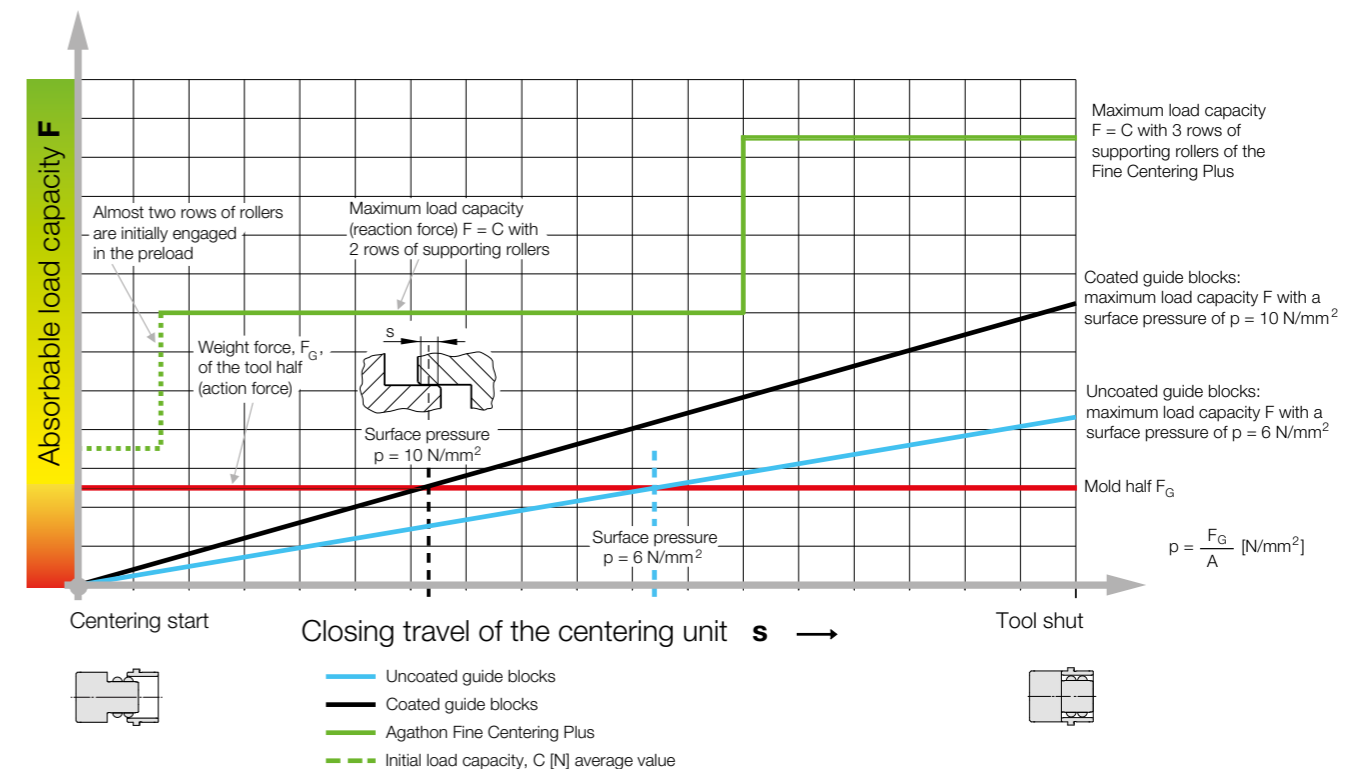

Agathon Fine Centering Plus Standard 7990

The Universal – Standard 7990

Centering at main separation
Centering of hybrid injection molds

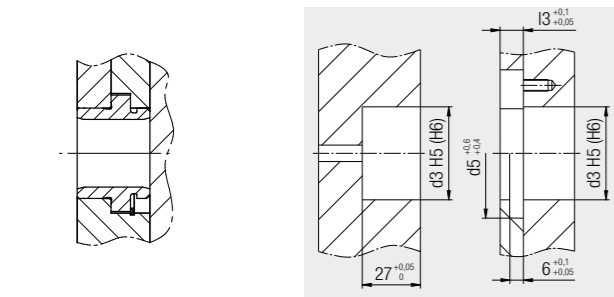
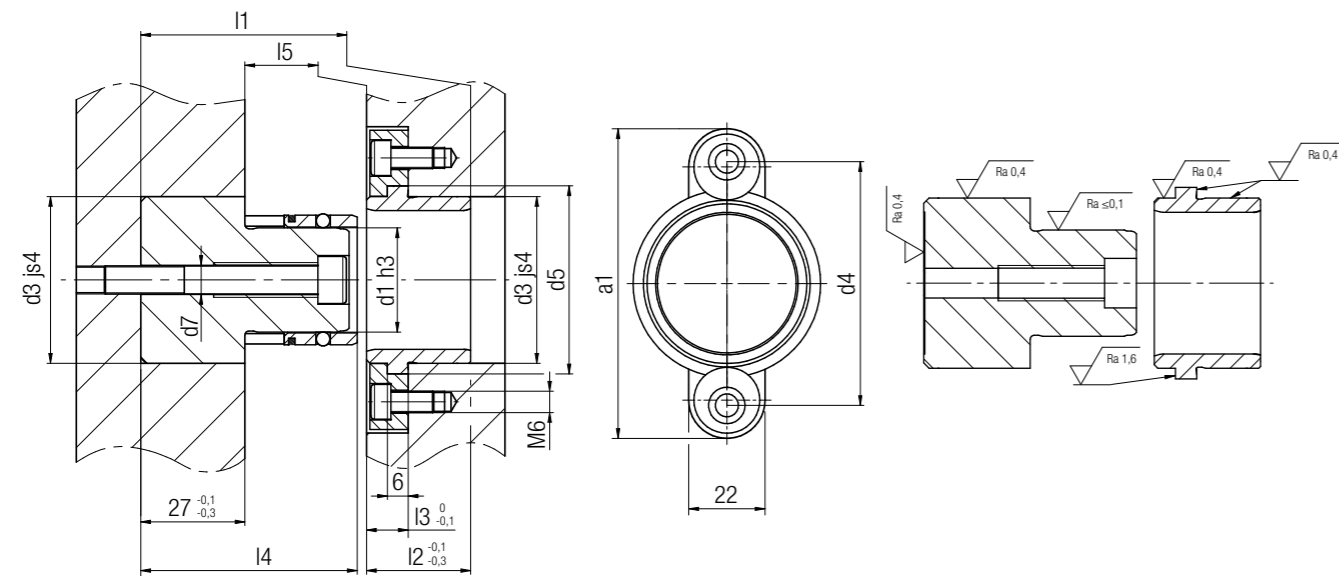

- d1 = Centering pillar, diameter tolerance ISO h3, superfinish ground
- d3 = Outer diameter of the centering pillar and flanged bush to fit js4/H5(H6)
- d4 = Reference diameter for clamps (clamps A-8001.000.001), mounting thread: M6x18
- d5 = Outer diameter of the flanged bush
- a1 = Installation space required for the clamps, alternative arrangement: 120°
- d7 = Center hole for mounting the guide pillar, including auxiliary thread for easy removal
- l1 = Nominal length of the centering unit in the fully closed position
- l2 = Total length of the centering bush
- l3 = Installation depth of the centering bush
- l4 = Total length of the centering pillar
- l5 = Total working length of the guide

Bush can be installed on both sides

Installation situation

Material of the bushes, rollers: 100Cr6 – 1.3505, hardened 62 - 64 HRC; Centering pillar: 16MnCr5, hardened 61 - 63 HRC.

Article	d1	d3	d4	d5	a1	d7	l1	l2	l3	l4	l5	C, C ₀ [N] - Indicative value
7990.015.049	15	28	52	36	69	6.8 / M6	49.5	22.5	12	51.5	-14	Entry (C): 1400 Shut (C ₀): 4700
7990.025.054	25	40	64	48	81	8.5 / M8	54	27	12	55.5	-18	Entry (C): 2150 Shut (C ₀): 10800
7990.032.057	32	48	70	54	87	8.5 / M8	57	30	12	59.5	-20	Entry (C): 2750 Shut (C ₀): 13800
7990.050.072	50	70	96	80	113	8.5 / M8	72.5	45.5	12	74	-34	Entry (C): 4240 Shut (C ₀): 28200

C = dynamic load rating in N – Initial load capacity

C₀ = static load rating in N – Tool fully shut

Agathon Fine Centering Plus Standard 7992

Small applications – Standard 7992

Centering of the individual cavities
Centering at main separation for small or micro tools

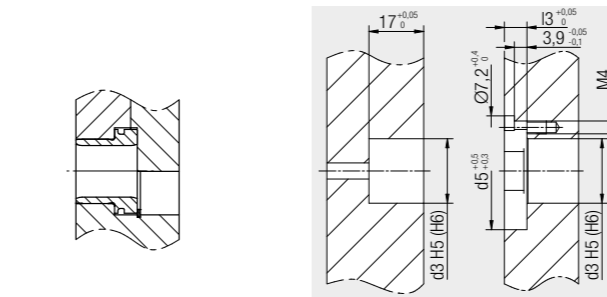
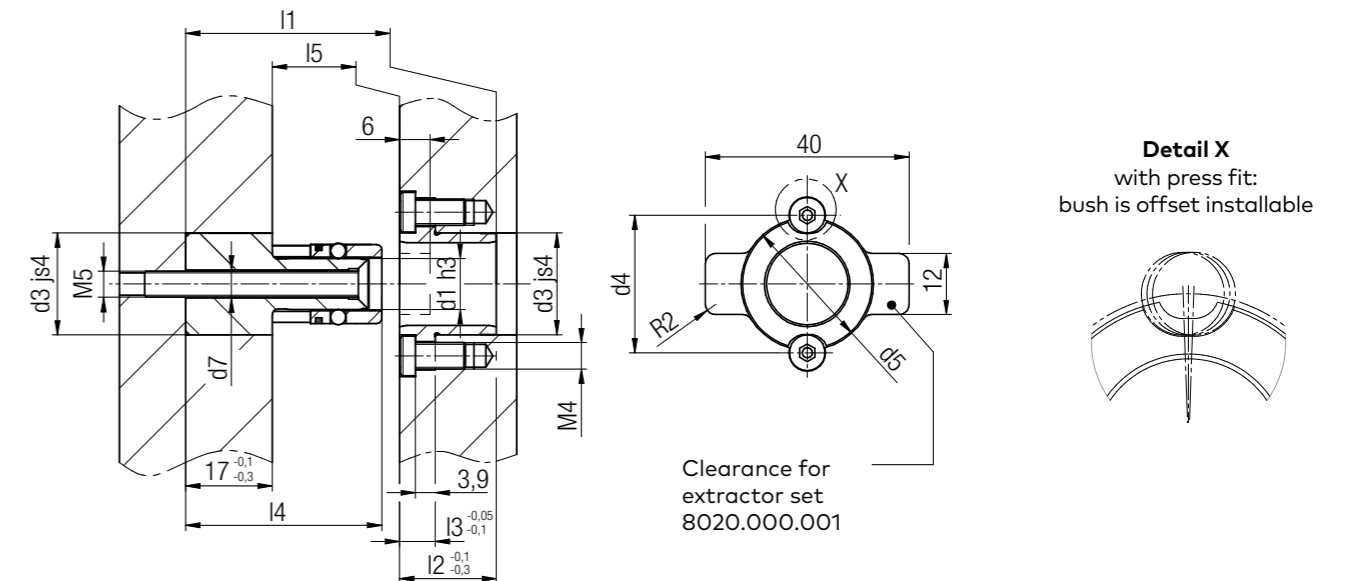

- d1 = Centering pillar, diameter tolerance ISO h3, superfinish ground
- d3 = Outer diameter of the centering pillar and flanged bush to fit js4/H5(H6)
- d4 = Reference diameter for mounting elements (cylindrical screws A-02157050, M4x10)
- d5 = Outer diameter of the flanged bush
- d7 = Center hole for mounting the guide pillar, including auxiliary thread for easy removal
- l1 = Nominal length of the centering unit in the fully closed position
- l2 = Total length of the centering bush
- l3 = Installation depth of the centering bush
- l4 = Total length of the centering pillar
- l5 = Total working length of the guide

Bush can be installed on both sides

Installation situation

Material of the bushes, rollers: 100Cr6 – 1.3505, hardened 62 - 64 HRC; Centering pillar: 16MnCr5, hardened 61 - 63 HRC.

Article	d1	d3	d4	d5	d7	l1	l2	l3	l4	l5	C, C ₀ [N] - Indicative value
7992.010.036	10	20	27	26	5.2 / M5	36	19	7	38.5	-11	Entry (C): 630 Shut (C ₀): 1050

C = dynamic load rating in N – Initial load capacity

C₀ = static load rating in N – Tool fully shut

Agathon Fine Centering Plus Standard 7993

For highest demands – Standard 7993

Longer centering stroke, ideal for high temperature applications

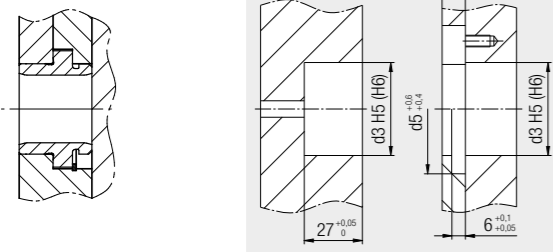
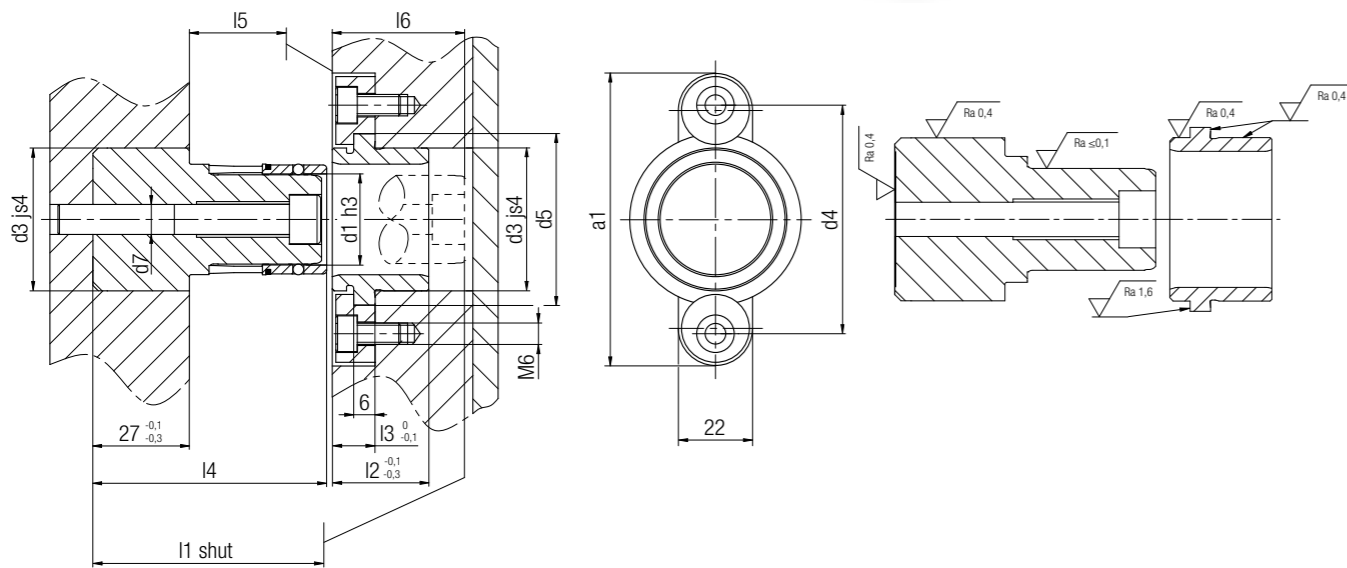

Bush can be installed on both sides

Installation situation

- d1 = Centering pillar, diameter tolerance ISO h3, superfinish ground
- d3 = Outer diameter of the centering pillar and flanged bush to fit js4/H5(H6)
- d4 = Reference diameter for clamps (clamps A-8001.000.001), mounting thread: M6x18
- d5 = Outer diameter of the flanged bush
- a1 = Installation space required for the clamps, alternative arrangement: 120°
- d7 = Center hole for mounting the guide pillar, including auxiliary thread for easy removal
- l1 = Nominal length of the centering unit in the fully closed position
- l2 = Total length of the centering bush
- l3 = Installation depth of the centering bush
- l4 = Total length of the centering pillar
- l5 = Total working length of the guide
- l6 = Pillar insertion depth

Material of the bushes, rollers: 100Cr6 – 1.3505, hardened 62 - 64 HRC; Centering pillar: 16MnCr5, hardened 61 - 63 HRC.

Article	d1	d3	d4	d5	a1	d7	l1	l2	l3	l4	l5	l6	C, C ₀ [N] - Indicative value
7993.015.059	15	28	52	36	69	6.8 / M6	59	22.5	12	61	-23	32	Entry (C): 1400 Shut (C ₀): 4700
7993.025.064	25	40	64	48	81	8.5 / M8	64	27	12	65.5	-28	37	Entry (C): 2150 Shut (C ₀): 10800
7993.040.067	40	58	82	66	99	8.5 / M8	67	40	12	69	-30	40	Entry (C): 3520 Shut (C ₀): 17600

C = dynamic load rating in N – Initial load capacity

C₀ = static load rating in N – Tool fully shut

Agathon Fine Centering Plus Standard 7995

For short stroke applications – Standard 7995

For guiding applications where the bushing is not exited

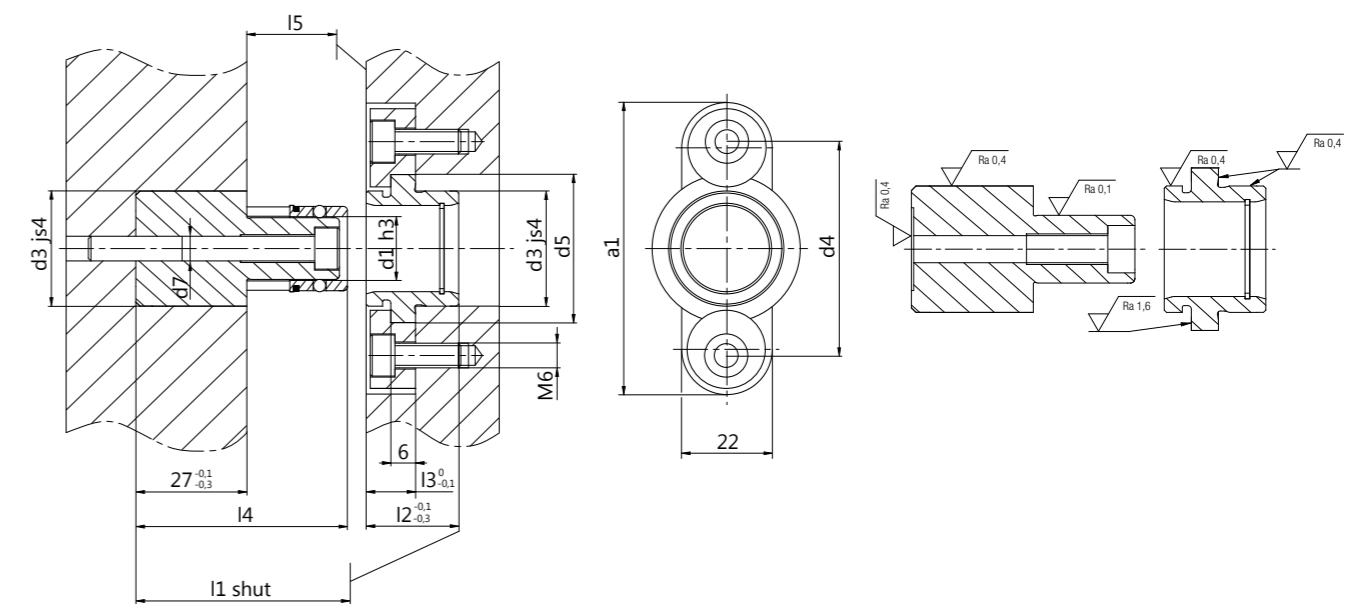

- d1 = Centering pillar, diameter tolerance ISO h3, superfinish ground
- d3 = Outer diameter of the centering pillar and flanged bush to fit js4/H5(H6)
- d4 = Reference diameter for clamps (clamps A-8001.000.001), mounting thread: M6x18
- d5 = Outer diameter of the flanged bush
- a1 = Installation space required for the clamps, alternative arrangement: 120°
- d7 = Center hole for mounting the guide pillar, including auxiliary thread for easy removal
- l1 = Nominal length of the centering unit in the fully closed position
- l2 = Total length of the centering bush
- l3 = Installation depth of the centering bush
- l4 = Total length of the centering pillar
- l5 = Total working length of the guide

Material of the bushes, rollers: 100Cr6 – 1.3505, hardened 62 - 64 HRC; Centering pillar: 16MnCr5, hardened 61 - 63 HRC.

Article	d1	d3	d4	d5	a1	d7	l1	l2	l3	l4	l5	C, C ₀ [N] - Indicative value
7995.015.049	15	28	52	36	69	6.8 / M6	49.5	22.5	12	51.5	-14	Entry (C): 1400 Shut (C ₀): 4700
7995.025.054	25	40	64	48	81	8.5 / M8	54	27	12	55.5	-18	Entry (C): 2150 Shut (C ₀): 10800

C = dynamic load rating in N – Initial load capacity

C₀ = static load rating in N – Tool fully shut

Features and advantages

Standard 7990/2

- Thanks to a precise and axial positioning of the roller cage, almost 2 rows of rollers are preloaded at the centering start - this guarantees a high initial load capacity (C)
- Low wear due to rolling centering. Conventional flat centering systems achieve low-wear «sliding» centering only after sufficient overlapping of the two centering surfaces
- The design engineer is free to choose the arrangement and number of fine centering units to be installed

Applications

- Centering of main separation plane and individual centering of cavities, guiding the ejection plate
- Centering of hybrid injection molds
- Tool centering on the machine plate of the injection molding machine
- Deep-drawing and fine-blanking punching applications
- General machine applications requiring a zero-centering respectively backlash-free guide

Standard 7993

- The standard series 7993 has a centering stroke 15 increased by more than 50% compared to the initial standard 7990. As a result, it is now possible to also eject higher injection-molded parts in a gentle and precise manner
- The standard series 7993 is nearly 100% compatible with the original 7990 standard part. Exception: In closed condition, the pillar protrudes over the bush end; therefore, some clearance must be prepared behind the bush with the exception of d1=40
- Very low abrasion and low wear: The brass roller cage as well as new design features eliminate almost all mechanical wear – the centering devices are therefore suitable for clean room applications
- Thanks to the brass cage, the centering may be cleaned with various cleaning methods
- Temperature-resistant, approx. 170 °C / 338 °F
- These combined features, compared to the initial standard 7990, provide a significantly higher centering capacity and allow a much wider range of applications

Applications

- Centering of main separation plane and individual centering of cavities, guiding the ejection plate
- Centering of hybrid injection molds
- Tool centering on the machine plate of the injection molding machine
- Deep-drawing and fine-blanking punching applications
- General machine applications requiring a zero-centering respectively backlash-free guide

Standard 7995

- The bushing is equipped with a stop. As a result, the centering pillar with roller cage does not necessarily have to exit the preload during each cycle. That is, the cage remains in the intended position at all times
- Otherwise, the short-stroke standard 7995 corresponds 100% to the original standard 7990. The bushing can not be installed on both sides

Applications

- Mold construction: guidance of ejector stroke and ventilation stroke
- General mechanical engineering: for recurring sequences with short stroke, the pillar does not exit the preload – or constant short stroke application

Calculation example

$$F_G = m \times g = 500\text{kg} \times 9.81\text{m/s}^2 = 4905\text{N}$$

$$\text{Cent}_n = \frac{F_G}{C} = \frac{4905\text{N}}{1400\text{N}} = 3.5 = 4 \times \text{A-7990.015.049}$$

$$C_n = 4 \times C = 4 \times 1400\text{N} = 5600\text{N} > \text{when } 4 \text{ fine centering units are used } \text{A-7990.015.049}$$

$$\text{Cent}_n = \frac{F_G}{C} = \frac{4905\text{N}}{2150\text{N}} = 2.3 = 3 \times \text{A-7990.025.054}$$

$$C_n = 3 \times C = 3 \times 2150\text{N} = 6450\text{N} > \text{when } 3 \text{ fine centering units are used } \text{A-7990.025.054}$$

Initial load capacity C = Average value of almost two rows of supporting rollers



Legend:

F_G = Weight force of a tool half = $m \times g$ [N]

Cent_n = Determination of the number of fine centering units

C = dynamic load rating of the individual fine centering units = initial load capacity [N], (see data sheet)

$C_n = C_1 + C_2 + C_3 + \dots + C_x$ load rating sum of all fine centering units used [N]

C_0 = static load rating of the individual fine centering units, in state Tool shut [N], (see data sheet)

$C_{0n} = C_{01} + C_{02} + C_{03} + \dots + C_{0x}$ load rating sum of all fine centering units used [N]

$F_q = C_{0n}$ = Lateral force by sliding the tool halves, caused by too small holding force [N]

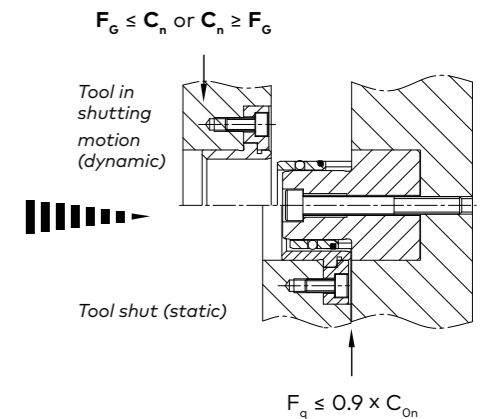

Mounting surface for the Fine Centering Plus

Depending on the application, two or more Fine Centering Plus units can be used.

The unique concept of the Fine Centering Plus units provides the design engineer with the freedom of choosing the arrangement and the number of units to be used.

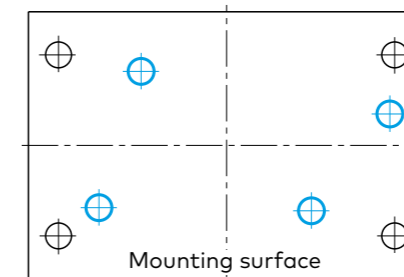

Excellent design freedom

- ⊗ Main guide
- ⊕ Can be freely arranged
- Mounting surface

Thermal expansion in injection molding

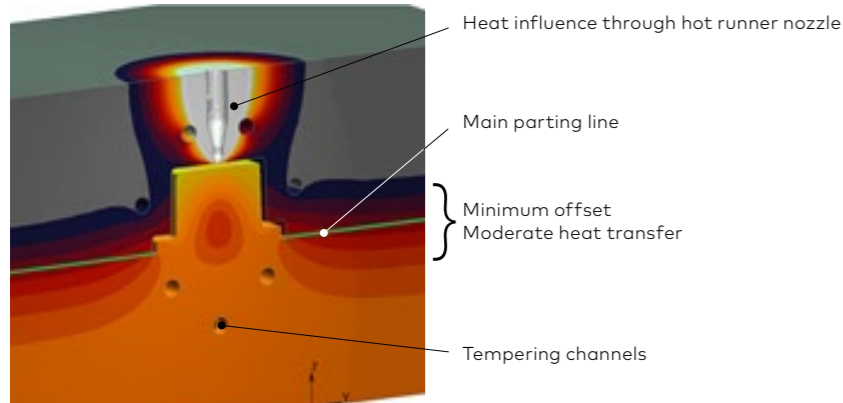

Conclusion:

For homogeneously tempered tools up to ΔT of 30 K, no problems are to be expected with thermal expansion.

- Case study: asymmetrically tempered tool, $\Delta T = 50$ K
- Temperature: Ejector side 90 °C (194 °F)
Nozzle side 40 °C (104 °F)
- Actual offset is reduced by a **factor of 3-5** by heat transfer at the tool separation!
- Analyzed offset at separation: 6.2 μm > Agathon centering can be used

More information can also be found in our fact-sheet.

Maintenance

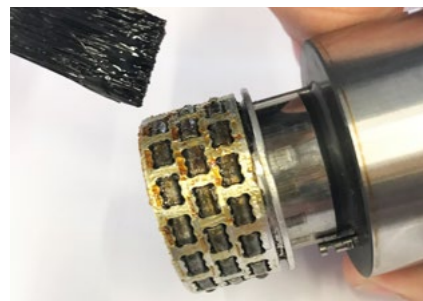

- After delivery: Remove rust inhibitor from the fine centering unit
- During maintenance: Remove old grease without leaving any residue
- Apply a new lubricating grease to the cage of the fine centering unit – see Agathon catalog for recommendations
- For cleanroom applications, excess grease can be wiped off with a fluff-free cloth
- Centering elements must be replaced when the preload is no longer present. Preventive replacement as part of normal maintenance is advisable



Fitting accuracy, machining the mounting holes

Position accuracy:

Mounting holes for pillar and bush must be within a maximum position deviation of 0.005 mm. The coordination of the slide elements must be accordingly performed in closed tool, so that no radial forces influence on the fine centering.

Perpendicularity:

Bush and pillar axis must be within a maximum position deviation of 0.005 mm per 100 mm, to the mold split line.

Installation depth:

The flatness of all axis bearing surfaces of the holes for the centering units should not vary by more than 0.05 mm.

Characteristics

Offset:

The Agathon Fine Centering Plus 7990/2, 7993, 7995 can correct an offset within the mold of up to 0.15 mm. However it is advisable to prealign the mold halves to within < 0.05 mm, using the main sliding guides / pillars.

Centering units:

Centering bush and pillar are manufactured to very accurate tolerances and matched to one another. It is important that the two are always installed together as a pair.

Solutions for multi-component tools on request.

Multiple centering

- Paired in requested batches
- Centering for turning and sliding tools

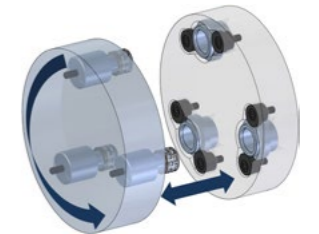

Removal

The centering pillar can be easily removed using conventional extractors or a sliding hammer, by means of the auxiliary thread.

Using the Agathon extractor kit, available for all sizes up to $\varnothing 32$ mm, the centering pillar can be removed via adapter and the centering bush via gripper.

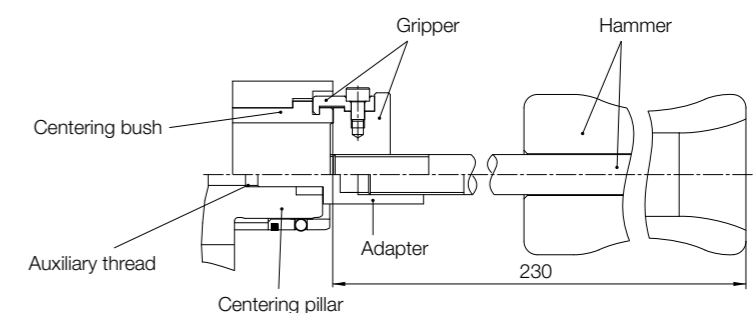

Article	Notes
8020.000.001	Case with extractor kit for all sizes up to $\varnothing 32$ mm including hammer

Other Agathon fine centering units

Agathon Mini Fine Centering

- Centering for highly precise and light centering tasks – inclusive for short-stroke applications
- For applications in punching and injection molds, mechanical engineering, robotics and automation
- Stick-slip-free movement, low wear, maximum precision and minimum space requirement
- Bushing and pillar unit are not paired and can be replaced individually
- Available as complete unit with bushing (Standard 7981), as pillar unit (Standard 7980) and as bushing (Standard 7989), each in diameters 8 and 10 mm



A-7981: Version with bushing



A-7980: Version without bushing



A-7989: Bushing